

# Vintner Series

Rev. 1/20/12

## Diamond Cube G2

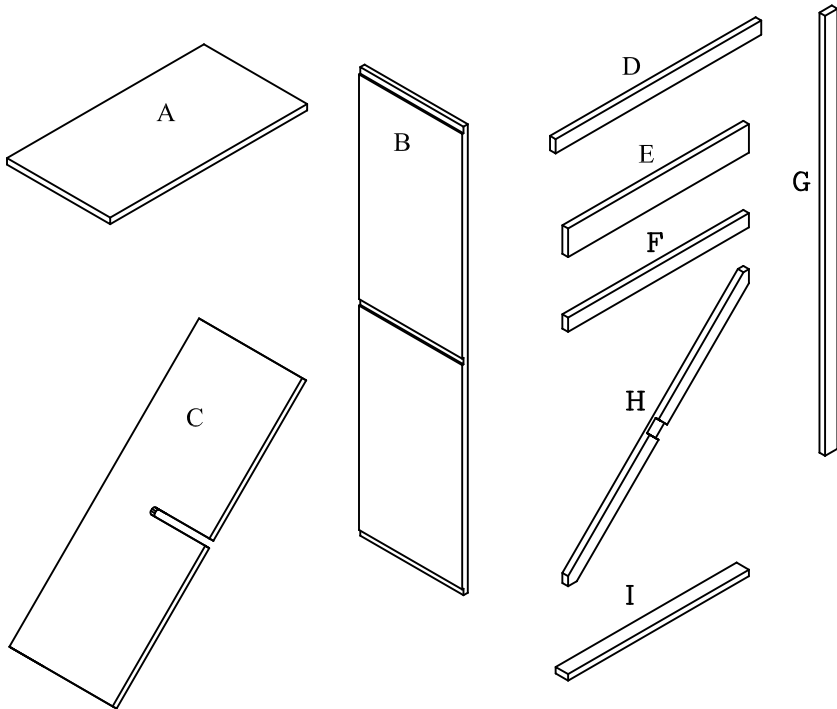
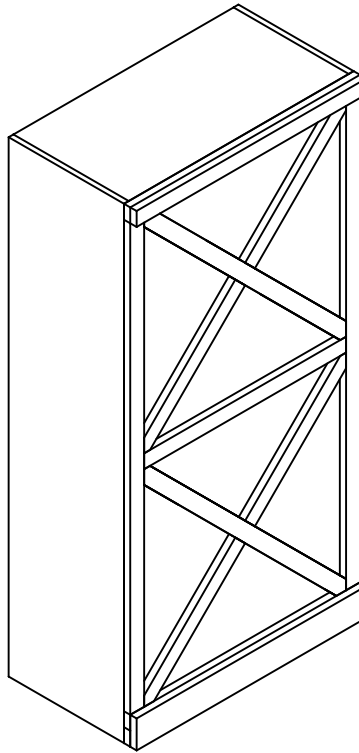

### Parts List

#	qty.	description
A	3	Top/Bottom/Middle
B	2	Sides
C	4	Interlock Boards
D	2	Top Trim
E	2	Bottom Trim
F	1	Mid Trim
G	2	Side Trim
H	4	Interlock Face Trim
I	2	Stackable Beam Supports
*	1	Screw driver bit
*	18	1 5/8" #6 Screws
*	1	Bag of nails
*	1	<b>Hardware Pack containing</b> 2 1" Corner Brace 2 plastic anchors 2 1" #8 screws 2 5/8" #6 screws

1. Attach top, bottom, middle and sides together with 1 5/8" #6 Screws.

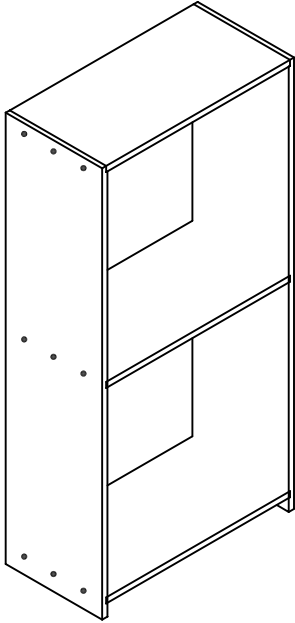

2. Join together 2 interlocking boards to form x-interlocks and slide into openings.

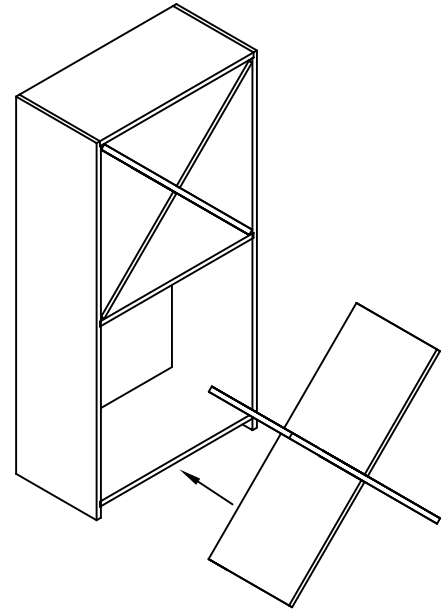

3. Attach (1) top trim, side trim pieces and (1) bottom trim with nails. Attach interlock face trim to interlocks with nails.

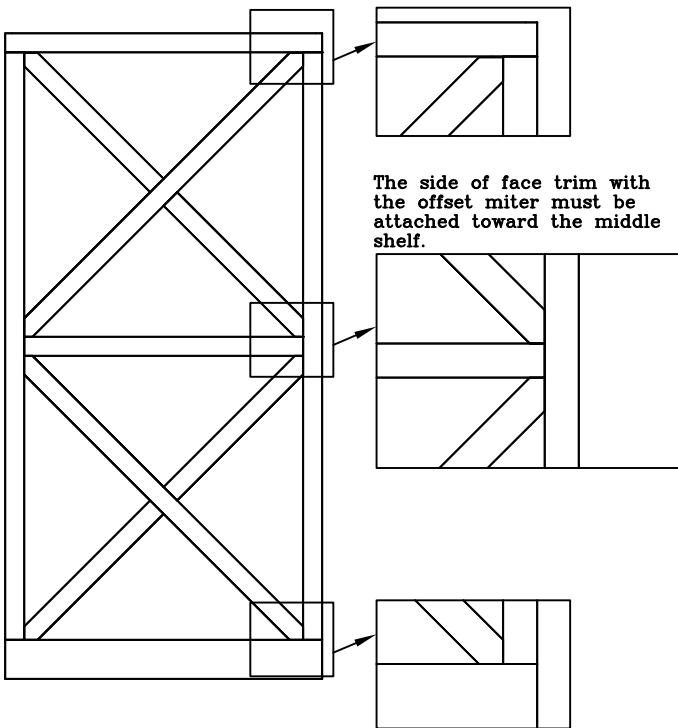

4. Attach second top trim to unit with nails.

If kit is going to be stacked with another kit follow trim kit instructions before attaching second bottom trim piece. If not then attach second bottom trim piece with nails.

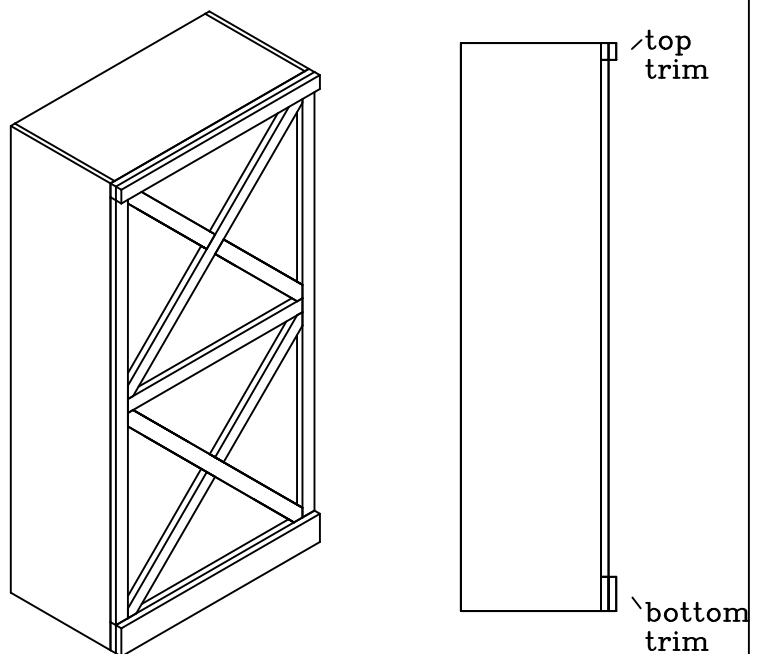

# Final Step

## Securing to wall

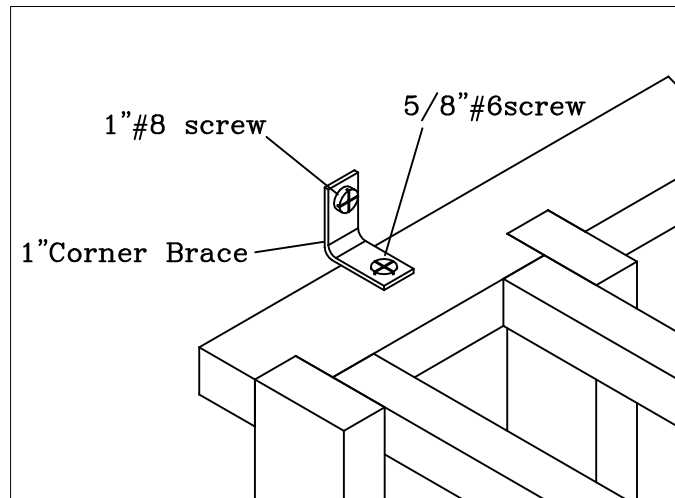

Note: due to ceiling height restrictions it may be necessary to attach Corner brace on under side of Spacer bar.

Secure rack to wall by attaching 1" corner brace to top back spacer bar (or solid top) of unit. You will have 1 brace on the left and 1 on the right.

If you are securing a kit that is stacked on top of another unit follow the instructions for installing trim kit before attaching to wall.

Attach the corner braces to one of the middle spacer bars, if you have a bin unit or diamond cube unit that will have other racks stacked on top of it.